



Standard Unit Dimensions:

Length:
2000mm

Width:
1500mm

Height:
2200mm

Colours/Finishes:

	RAL 9006 White Aluminium	RAL 7016 Anthracite Grey
BS 4800 10 A 07 Nimbus Grey	RAL 3020 Traffic Red	RAL 9005 Jet Black
BS 4800 14 C 39 Holly Green	RAL 1023 Traffic Yellow	BS 4800 00 A 05 Goose Grey
RAL 5015 Mid Blue	RAL 5013 Dark Blue	RAL 9016 Traffic White

The colours shown are a guide only.
Please check a colour chart to see the actual colour.

Product Information

Pay and display shelter, perfect for providing shelters on car parks. This shelter is ideal for pay and display machines, notice boards and other information centres, allowing people to stand out of the rain.

Features

- ClearView PETg UV sheeting giving excellent visibility
- Robust, tough construction
- Base plate or submerged fixing

Materials Used

- Welded end frames and purlin section made from heavy-duty box section assembled with anti-tamper high strength bolts
- Vandal resistant

Finish Options

- Hot dip galvanised to BS EN ISO 1461:2009
- Galvanised to BS EN ISO 1461:2009 & Polyester Powder Coated

Weather Resistance

Cladding is UV Stabilised
Wind resistant to 23m/s

Broxap Limited, Rowhurst Industrial Estate, Chesterton, Newcastle-under-Lyme, Staffordshire, ST5 6BD T: 01782 564411 E: info@broxap.com W: www.broxap.com



Fire Resistance

Cladding is fire tested to '1Y' for BS 476

Guarantees, Warranties, Design-Life and Life-Expectancies

- 25 year structural guarantee*
- 34 year (min) life expectancy for Hot Dip Galvanizing
- 8-10 year life expectancy on standard powder coatings
- 10-15 year life expectancy on Duplex (Zinc Coated) powder coatings
- 10 years' manufacturers guarantees* on cladding material(s)
- 10 years' warranty* on material (only)
- 12 months' warranty* on parts & labour

*Maintenance and other qualifying criteria apply

Options

- Installation service available

Diagram

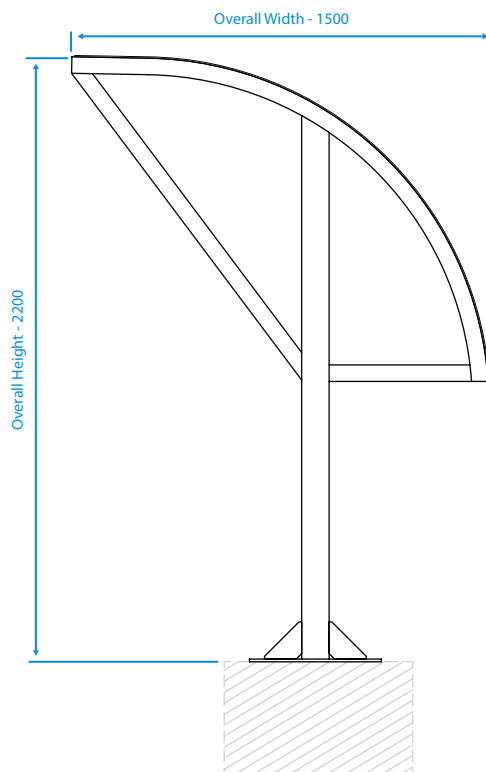

Installation

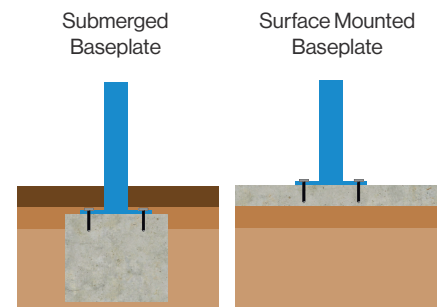

Standard Unit Dimensions:

Length:
2000mm

Width:
1500mm

Height:
2200mm

Colours/Finishes:

	RAL 9006 White Aluminium	RAL 7016 Anthracite Grey
BS 4800 10 A 07 Nimbus Grey	RAL 3020 Traffic Red	RAL 9005 Jet Black
BS 4800 14 C 39 Holly Green	RAL 1023 Traffic Yellow	BS 4800 00 A 05 Goose Grey
RAL 5015 Mid Blue	RAL 5013 Dark Blue	RAL 9016 Traffic White

The colours shown are a guide only.
Please check a colour chart to see the actual colour.

Broxap Limited, Rowhurst Industrial Estate, Chesterton, Newcastle-under-Lyme, Staffordshire, ST5 6BD T: 01782 564411 E: info@broxap.com W: www.broxap.com

