

Maelor Trafflex Open Top 90L Litter Bin BXMT/445/G



Standard Unit Dimensions:

Height: 700mm
Diameter: 570mm
Capacity: 90 Litres
Weight: 5kg

Colours/Finishes:

RAL 9005 Jet Black	RAL 9003 Signal White	RAL 1003 Signal Yellow
RAL 3020 Traffic Red	RAL 5015 Sky Blue	RAL 5003 Sapphire Blue
RAL 6017 May Green	RAL 6004 Blue Green	RAL 7030 Stone Grey
RAL 7009 Green Grey	RAL 8014 Sepia Brown	

The colours shown are a guide only.
Please check a colour chart to see the
actual colour.

Product Information

Tough and robust 90 litre open top plastic litter bin with reinforced galvanised framework. Every unit in the Maelor range is manufactured in part from recycled materials.

Features

- Galvanised frame as standard
- Steel frame supplied with base plate and fixing holes
- One piece "lock-on" lightweight cover
- Cover made from recyclable material
- Chamfered edges ensure rubbish is directed into the liner with no overspill between liner and outer case
- Removal of outer case and liner allows cleaning of area beneath and around location of the bin
- Black as standard, other colours available at additional cost
- To empty lift the lightweight cover over the frame using the maelor key provided

Materials Used

- HDPE

Broxap Limited, Rowhurst Industrial Estate, Chesterton, Newcastle-under-Lyme, Staffordshire, ST5 6BD T: 01782 564411 E: info@broxap.com W: www.broxap.com



ISO 9001
Quality
Management
Systems
CERTIFIED

ISO 14001
Environmental
Management
CERTIFIED

ISO 45001
Occupational
Health and Safety
Management
CERTIFIED



Maelor Trafflex Open Top 90L Litter Bin BXMT/445/G

Options

- Other RAL/BS colours available on request for additional cost

Diagram

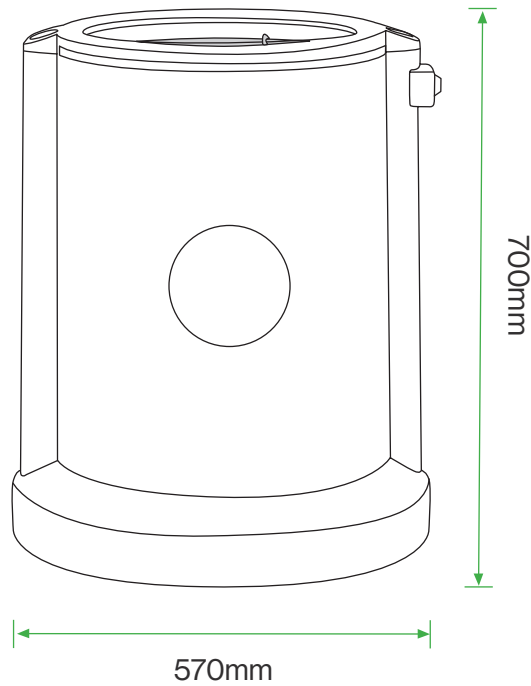

Standard Unit Dimensions:

Height: 700mm
Diameter: 570mm
Capacity: 90 Litres
Weight: 5kg

Colours/Finishes:

RAL 9005 Jet Black	RAL 9003 Signal White	RAL 1003 Signal Yellow
RAL 3020 Traffic Red	RAL 5015 Sky Blue	RAL 5003 Sapphire Blue
RAL 6017 May Green	RAL 6004 Blue Green	RAL 7030 Stone Grey
RAL 7009 Green Grey	RAL 8014 Sepia Brown	

The colours shown are a guide only.
Please check a colour chart to see the
actual colour.

Broxap Limited, Rowhurst Industrial Estate, Chesterton, Newcastle-under-Lyme, Staffordshire, ST5 6BD T: 01782 564411 E: info@broxap.com W: www.broxap.com



ISO 9001
Quality
Management
Systems
CERTIFIED

ISO 14001
Environmental
Management
CERTIFIED

ISO 45001
Occupational
Health and Safety
Management
CERTIFIED

