

Derby Round Recycling Bin BX45G 2554-RC



Standard Unit Dimensions:

Height: 1110mm
Diameter: 580mm
Capacity: 130 Litres
Weight: 80kg

Colours/Finishes:

RAL 6005 Moss Green	RAL 7016 Anthracite Grey	RAL 9005 Jet Black
RAL 9006 White Aluminium	RAL 5015 Sky Blue	RAL 5002 Ultramarine Blue
RAL 4010 Telemagenta	RAL 3020 Traffic Red	RAL 1023 Traffic Yellow
BS 4800 14 C 39 Holly Green		

The colours shown are a guide only.
Please check a colour chart to see the actual colour.

Product Information

The Derby Round Recycling bin is a recycling version of our Derby Round Litter Bin. The recycling bin is available in capacities of 80 or 130 litres.

Features

- 2mm Galvanized Steel
- Laser cut LITTER lettering beneath each posting aperture, with a gold backing plate
- Any combination of graphics to identify waste products, e.g. cans, paper, glass bottles, plastic bottles, mixed waste, etc.
- A choice of aperture shape to suit waste
- 0.7mm galvanized steel liner with safety top edge and 2 handles
- 10mm heavy duty solid steel base
- 20mm heavy duty stainless steel pivot hinge
- Stainless steel slam lock mechanism
- Hexagonal key operated heavy duty lock
- Powder galvanized prime and polyester powder coat (black as standard)
- Stainless steel escutcheons

Materials Used

- 2mm galvanized steel
- 10mm galvanized steel base
- 20mm stainless steel bar hinges

Broxap Limited, Rowhurst Industrial Estate, Chesterton, Newcastle-under-Lyme, Staffordshire, ST5 6BD T: 01782 564411 E: info@broxap.com W: www.broxap.com



ISO 9001
Quality Management Systems
CERTIFIED

ISO 14001
Environmental Management
CERTIFIED

ISO 45001
Occupational Health and Safety Management
CERTIFIED



Derby Round Recycling Bin BX45G 2554-RC

Guarantees & Warranties

- 12 Year Anti-Perforation Warranty*
- 12 Year Galvanised Steel Base Warranty*
- 2 Year Parts & Labour Guarantee*

*Maintenance and other qualifying criteria apply

Diagram

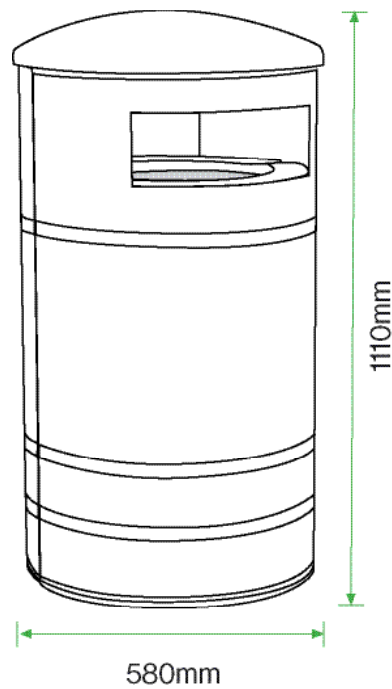

Standard Unit Dimensions:

Height: 1100mm
Diameter: 580mm
Capacity: 130 Litres
Weight: 80kg

Colours/Finishes:

RAL 6005 Moss Green	RAL 7016 Anthracite Grey	RAL 9005 Jet Black
RAL 9006 White Aluminium	RAL 5015 Sky Blue	RAL 5002 Ultramarine Blue
RAL 4010 Telemagenta	RAL 3020 Traffic Red	RAL 1023 Traffic Yellow
BS 4800 14 C 39 Holly Green		

The colours shown are a guide only.
Please check a colour chart to see the actual colour.

Broxap Limited, Rowhurst Industrial Estate, Chesterton, Newcastle-under-Lyme, Staffordshire, ST5 6BD T: 01782 564411 E: info@broxap.com W: www.broxap.com



ISO 9001
Quality Management Systems
CERTIFIED

ISO 14001
Environmental Management
CERTIFIED

ISO 45001
Occupational Health and Safety Management
CERTIFIED

