

Seating Specification Sheet

Sneyd Hill Picnic Unit with Wheelchair Access

BX713954-1

broxap[®]
street furniture



Standard Unit Dimensions:

Length: 2100mm
Width: 1300mm
Height: 780mm
Seat Height: 490mm
Weight: 95kg

Colours/Finishes:

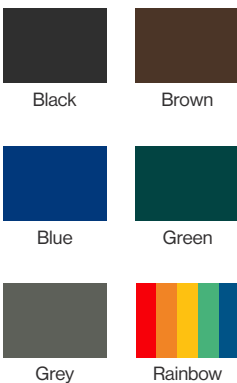

The colours shown are a guide only. Please check a colour chart to see the actual colour.

Product Information

Perfect for schools, hospitality venues and visitor locations, this recycled plastic picnic unit supports inclusivity with wheelchair access points. Made from a selection of waste plastics, the unit is completely weatherproof.

Features

- Supported by two 'A' frames for strength
- Constructed from recycled plastic
- Freestanding as standard
- Extended table top to accommodate wheelchair users

Materials Used

- Recycled Plastic

Options

- Optional fixing kits available

Broxap Limited, Rowhurst Industrial Estate, Chesterton, Newcastle-under-Lyme, Staffordshire, ST5 6BD T: 01782 564411 E: info@broxap.com W: www.broxap.com

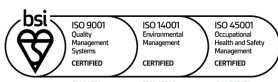

Seating Specification Sheet

Sneyd Hill Picnic Unit with Wheelchair Access

BX713954-1



Diagram

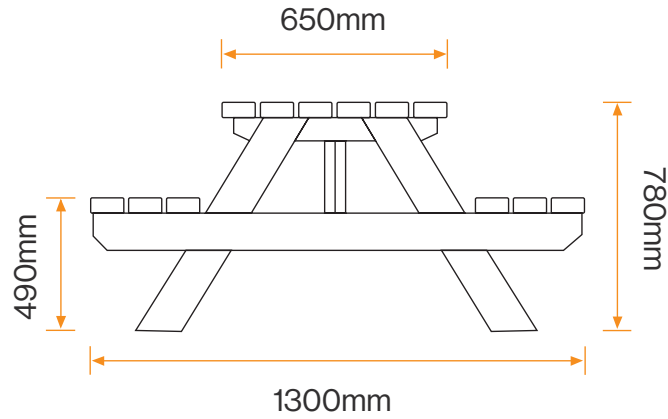

Installation

Free Standing Picnic Bench

Root/Submerged Fixing

Surface Mounted Baseplate



Standard Unit Dimensions:

Length: 2100mm
 Width: 1300mm
 Height: 780mm
 Seat Height: 490mm
 Weight: 95kg

Colours/Finishes:

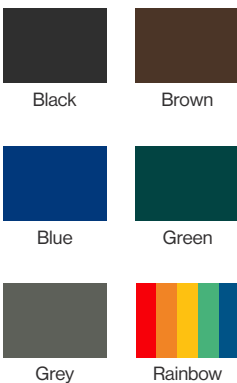

The colours shown are a guide only. Please check a colour chart to see the actual colour.

Broxap Limited, Rowhurst Industrial Estate, Chesterton, Newcastle-under-Lyme, Staffordshire, ST5 6BD T: 01782 564411 E: info@broxap.com W: www.broxap.com

