













Merthyr Cycle Stand BXMW/MER



Standard Unit Dimensions:

Height: 800mm
Width: 750mm
Capacity: 2 Cycles

Colours/Finishes:

 Galvanised Only	 RAL 9006 White Aluminium	 RAL 7016 Anthracite Grey
 BS 4800 10 A 07 Nimbus Grey	 RAL 3020 Traffic Red	 RAL 9005 Jet Black
 BS 4800 14 C 39 Holly Green	 RAL 1023 Traffic Yellow	 BS 4800 00 A 05 Goose Grey
 RAL 5015 Mid Blue	 RAL 5013 Dark Blue	 RAL 9016 Traffic White

The colours shown are a guide only.
Please check a colour chart to see the actual colour.

Product Information

The Merthyr Cycle Stand is a tubular cycle stand with crossbar and laser cut cycle motif.

Features

- Tubular cycle stand with crossbar and laser cut cycle motif
- Available in 50mm dia. steel hot dipped galvanised
- Stainless steel (£POA)
- Base plate or submerged fixing
- Can contribute towards gaining ENE8 credits when used in the appropriate situation, under the Code for Sustainable Homes
- BREEAM and Code for Sustainable Homes Compliant

Materials Used

- Framework - Mild Steel

Finish Options

- Galvanised to BS EN ISO 1461:2009
- Galvanised to BS EN ISO 1461:2009 & Polyester Powder Coated

Broxap Limited, Rowhurst Industrial Estate, Chesterton, Newcastle-under-Lyme, Staffordshire, ST5 6BD T: 01782 564411 E: info@broxap.com W: www.broxap.com



ISO 9001
Quality Management Systems
CERTIFIED

ISO 14001
Environmental Management
CERTIFIED

ISO 45001
Occupational Health and Safety Management
CERTIFIED



Merthyr Cycle Stand BXMW/MER

Guarantees, Warranties, Design-Life and Life-Expectancies

- 34 year (min) life expectancy for Hot Dip Galvanizing
- 8-10 year life expectancy on standard powder coatings
- 10-15 year life expectancy on Duplex (Zinc Coated) powder coatings
- 12 months' warranty* on parts & labour

*Maintenance and other qualifying criteria apply

Options

- Available in a range of colours
- Root fixed or base plated options available

Diagram

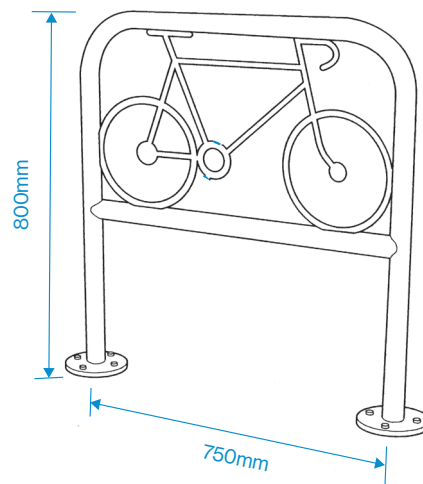

Standard Unit Dimensions:

Height: 800mm
Width: 750mm
Capacity: 2 Cycles

Colours/Finishes:

Galvanised Only	RAL 9006 White Aluminium	RAL 7016 Anthracite Grey
BS 4800 10 A 07 Nimbus Grey	RAL 3020 Traffic Red	RAL 9005 Jet Black
BS 4800 14 C 39 Holly Green	RAL 1023 Traffic Yellow	BS 4800 00 A 05 Goose Grey
RAL 5015 Mid Blue	RAL 5013 Dark Blue	RAL 9016 Traffic White

The colours shown are a guide only.
Please check a colour chart to see the actual colour.

Broxap Limited, Rowhurst Industrial Estate, Chesterton, Newcastle-under-Lyme, Staffordshire, ST5 6BD T: 01782 564411 E: info@broxap.com W: www.broxap.com



ISO 9001
Quality Management Systems
CERTIFIED

ISO 14001
Environmental Management
CERTIFIED

ISO 45001
Occupational Health and Safety Management
CERTIFIED

