



### Standard Unit Dimensions:

Bespoke sizes to suit customer requirements

### Colours/Finishes:

|                                |                             |                               |
|--------------------------------|-----------------------------|-------------------------------|
| Galvanised Only                | RAL 9006<br>White Aluminium | RAL 7016<br>Anthracite Grey   |
| BS 4800 10 A 07<br>Nimbus Grey | RAL 3020<br>Traffic Red     | RAL 9005<br>Jet Black         |
| BS 4800 14 C 39<br>Holly Green | RAL 1023<br>Traffic Yellow  | BS 4800 00 A 05<br>Goose Grey |
| RAL 5015<br>Mid Blue           | RAL 5013<br>Dark Blue       | RAL 9016<br>Traffic White     |

The colours shown are a guide only. Please check a colour chart to see the actual colour.

## Product Information

The Aquinas is a contemporary canopy, which demonstrates a fresh modern aesthetic. Suited to any modern environment, the Aquinas is a multi-functional covering available in a range of colours. This attractive bespoke monopitch canopy incorporates a discreet central leg and removes the appearance of uprights supporting the canopy.

The toughened glass planar roof provides clean lines and overall style, creating a contemporary looking structure.

## Features

- Mild steel structural framework
- Galvanized and powder coated finish
- Stainless steel grade 316 glazing spiders
- 10mm toughened glazed roof. Specialist glass-sealed joints between each panel
- Aesthetically pleasing simple design
- Welded end frames and purlin section made from heavy duty box section
- Assembled with anti-tamper high strength bolts
- Hot dipped galvanized to BS EN ISO 1461:2009

## Materials Used

- Framework - Mild steel
- Cladding - Toughened Laminated Glass

## Finish Options (Framework)

- Galvanised to BS EN ISO 1461:2009
- Galvanised to BS EN ISO 1461:2009 & Polyester Powder Coated

Broxap Limited, Rowhurst Industrial Estate, Chesterton, Newcastle-under-Lyme, Staffordshire, ST5 6BD T: 01782 564411 E: info@broxap.com W: www.broxap.com



ISO 9001  
Quality Management Systems  
CERTIFIED

ISO 14001  
Environmental Management  
CERTIFIED

ISO 45001  
Occupational Health and Safety Management  
CERTIFIED



## Aquinas BXMW/AQU

### Weather Resistance

Cladding is UV Stabilised  
Wind resistant to 23m/s

### Fire Resistance

Cladding is fire tested to '1Y' for BS 476

### Guarantees, Warranties, Design-Life and Life-Expectancies

- 25 year structural guarantee\*
- 34 year (min) life expectancy for Hot Dip Galvanizing
- 8-10 year life expectancy on standard powder coatings
- 10-15 year life expectancy on Duplex (Zinc Coated) powder coatings
- 10 years' manufacturers guarantees\* on cladding material(s)
- 10 years' warranty\* on material (only)
- 12 months' warranty\* on parts & labour

\*Maintenance and other qualifying criteria apply

### Options

- Glazed Roof Cladding in Stainless steel grade 316 glazing spiders
- Opal Cladding on the roof and side panels
- Powder Coating to a wide range of colours
- UPVC or Aluminium Guttering
- LED lighting or solar lighting
- Full installation service

#### Standard Unit Dimensions:

Bespoke sizes to suit customer requirements

#### Colours/Finishes:

|                                |                             |                               |
|--------------------------------|-----------------------------|-------------------------------|
|                                | RAL 9006<br>White Aluminium | RAL 7016<br>Anthracite Grey   |
| BS 4800 10 A 07<br>Nimbus Grey | RAL 3020<br>Traffic Red     | RAL 9005<br>Jet Black         |
| BS 4800 14 C 39<br>Holly Green | RAL 1023<br>Traffic Yellow  | BS 4800 00 A 05<br>Goose Grey |
| RAL 5015<br>Mid Blue           | RAL 5013<br>Dark Blue       | RAL 9016<br>Traffic White     |

The colours shown are a guide only.  
Please check a colour chart to see the actual colour.

### Diagram

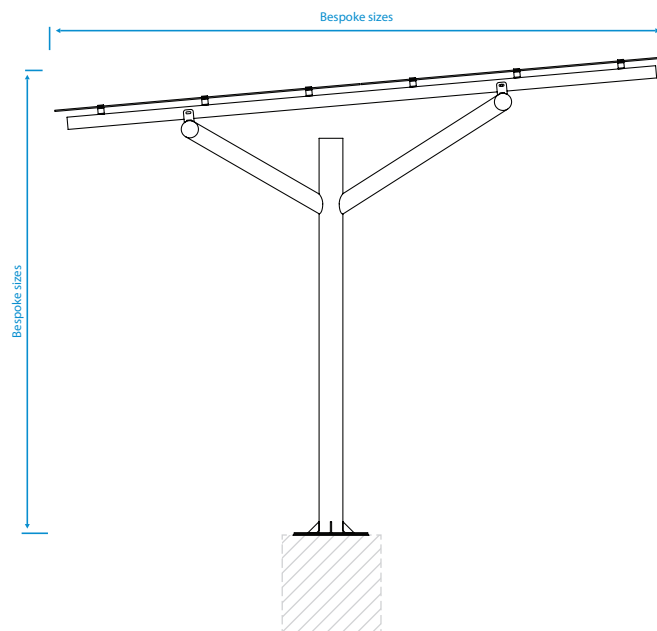

### Installation

