

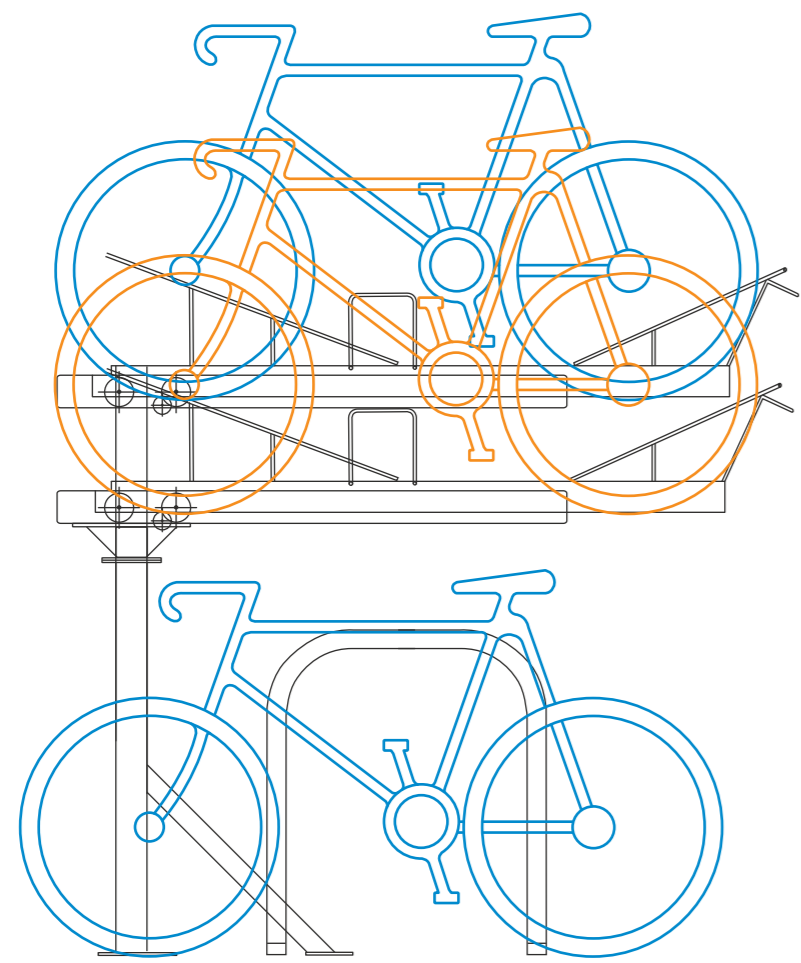

Additional information for maintenance can be found here on the Broxap website

# Eco-Riser Two-Tier Cycle Parking Operating Instructions



The Diagram above shows an Eco-Riser Two-Tier Cycle Rack in full use.

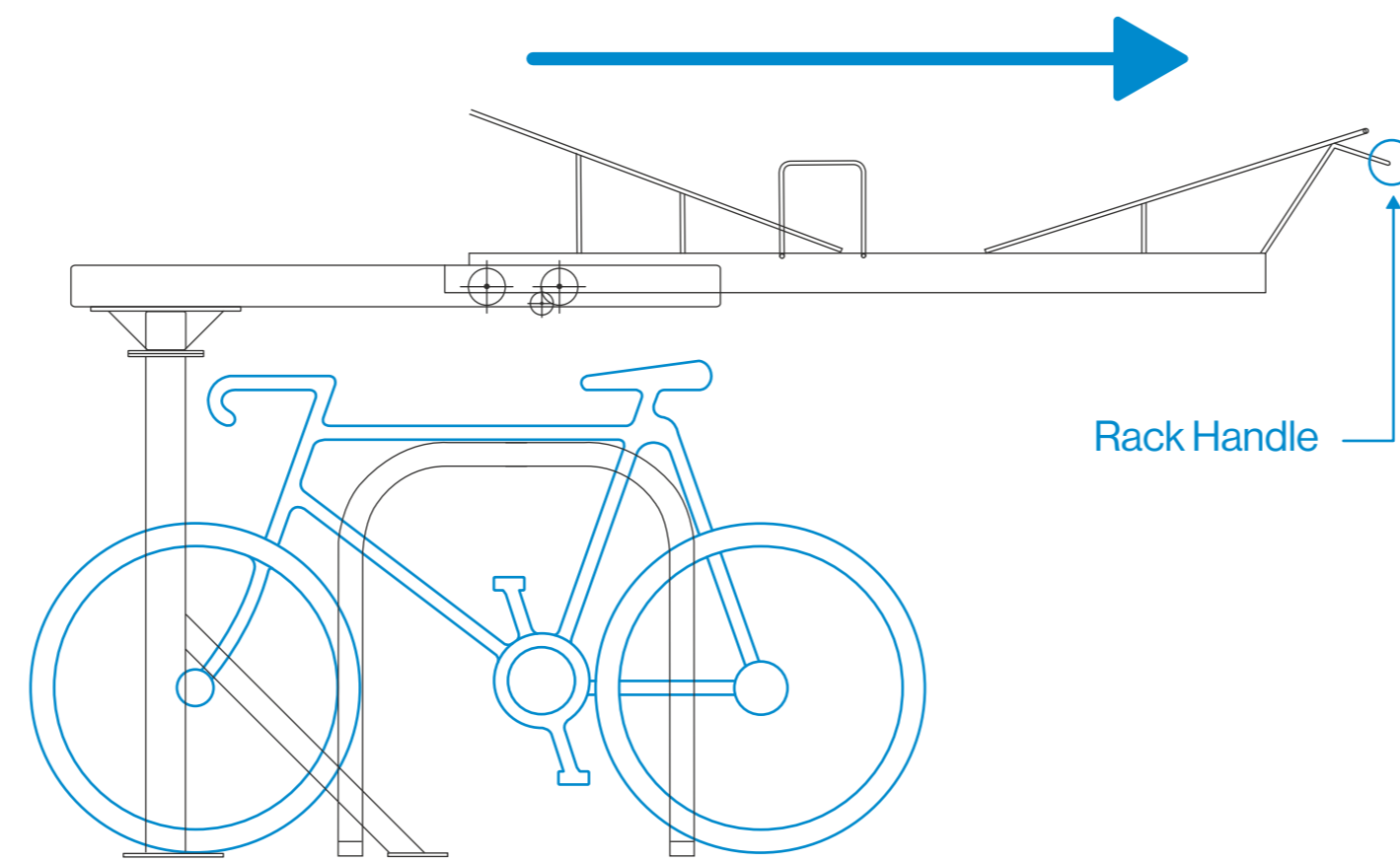

**1** When releasing the cycle rack you must take the handle and lift slightly, Then start to carefully pull cycle rack towards you.

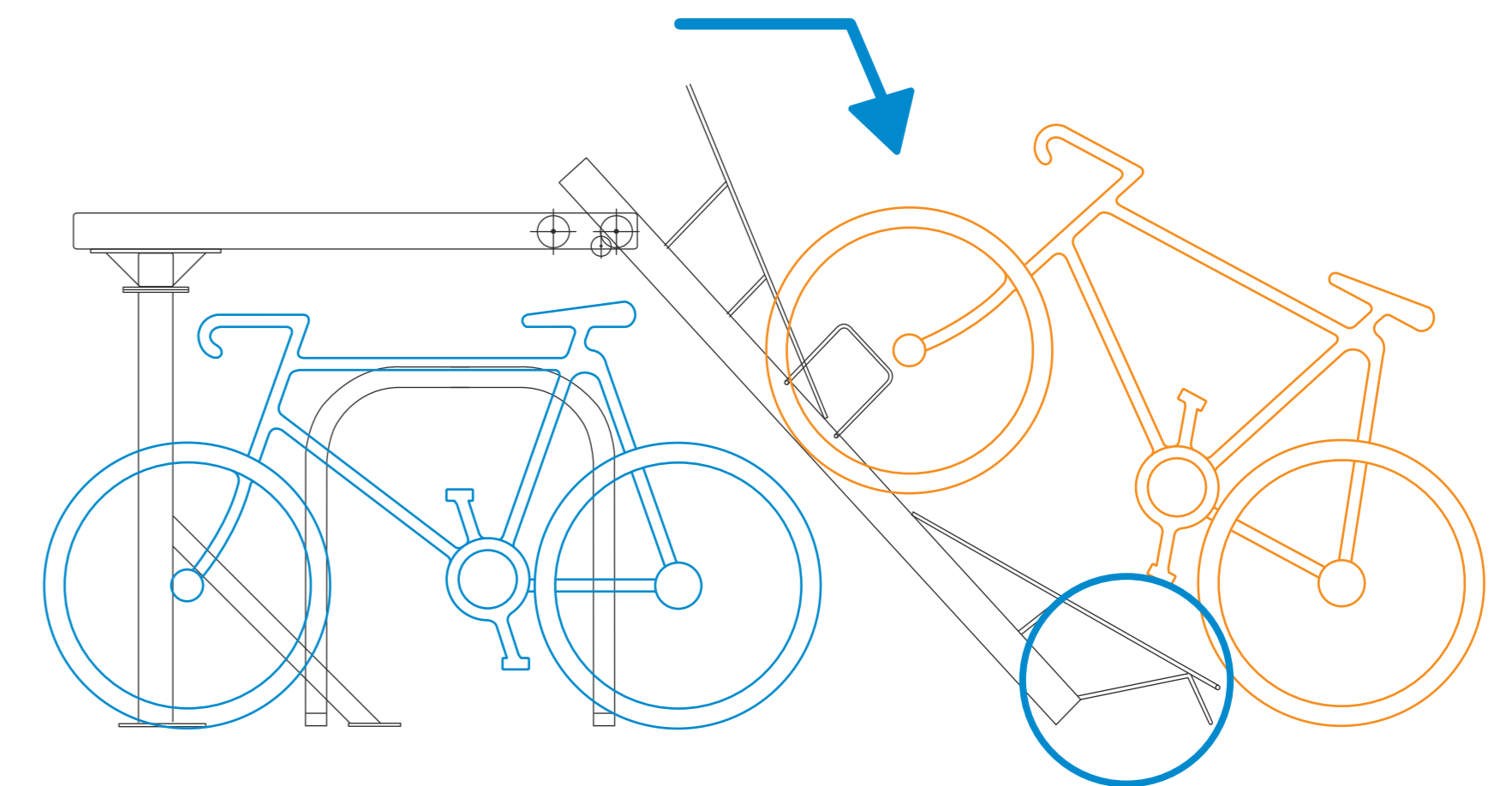

**2** When the rack is fully extended carefully lower the rack placing it down on the ground (as shown above).

**3** Lift the front wheel of the bicycle in to the tray.

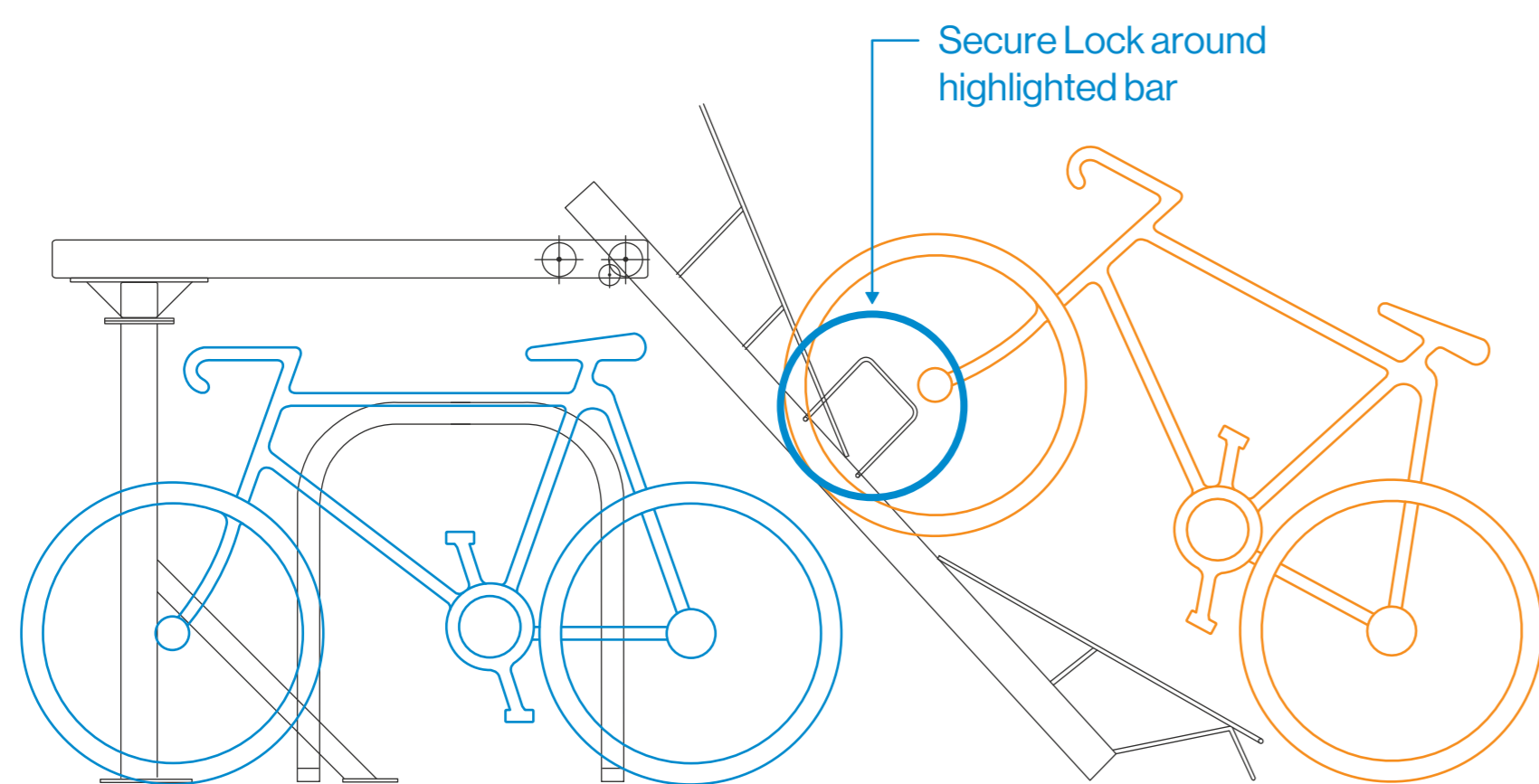

**4** Take the bicycle firmly by the seat and the handlebar and lift the back wheel into the tray.

**5** Using a locking device(not supplied) secure the bicycle to the tray.

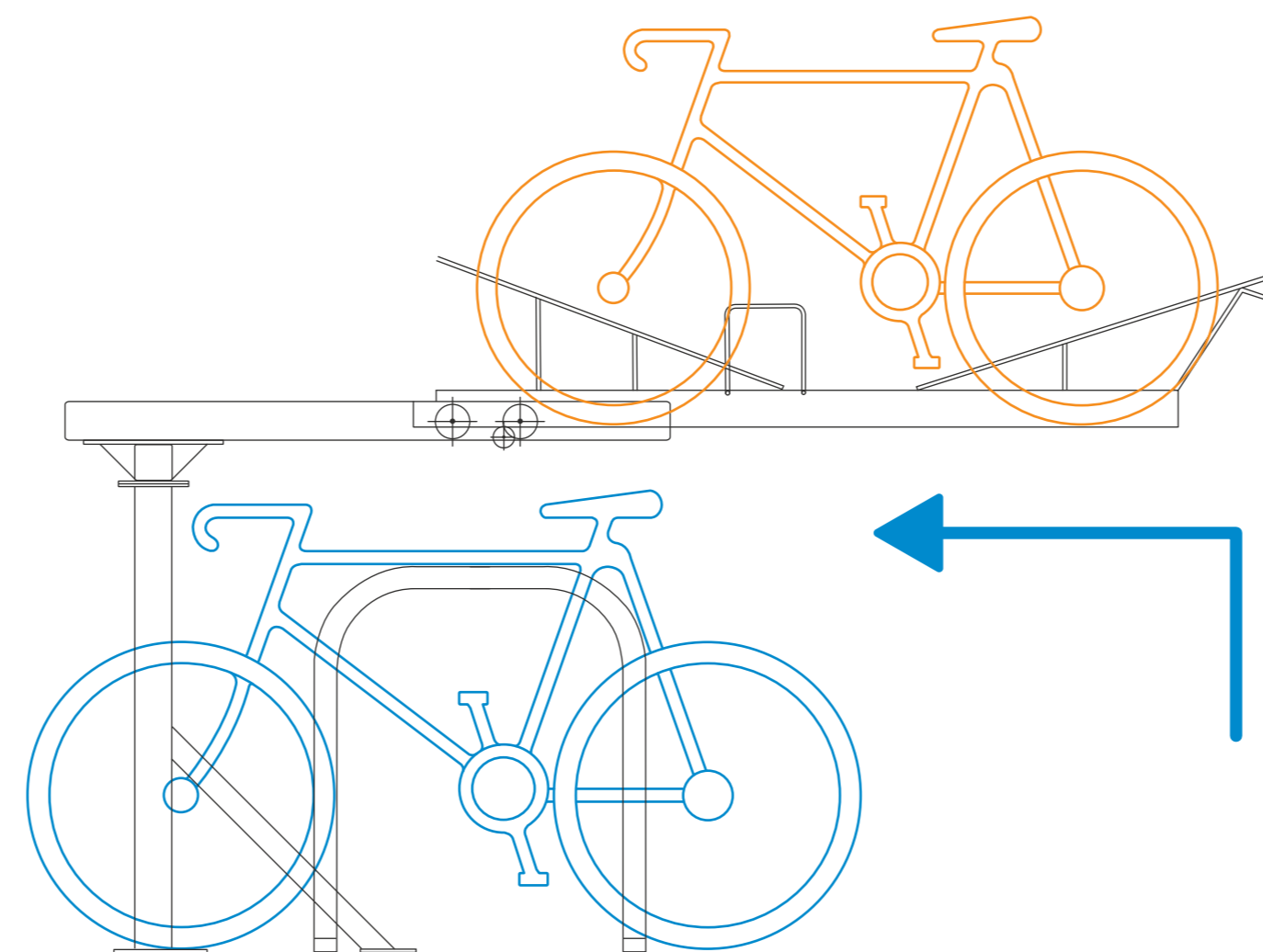

**6** Now the bicycle is securely attached to the tray. Take the rack handle and carefully lift rack from the ground.

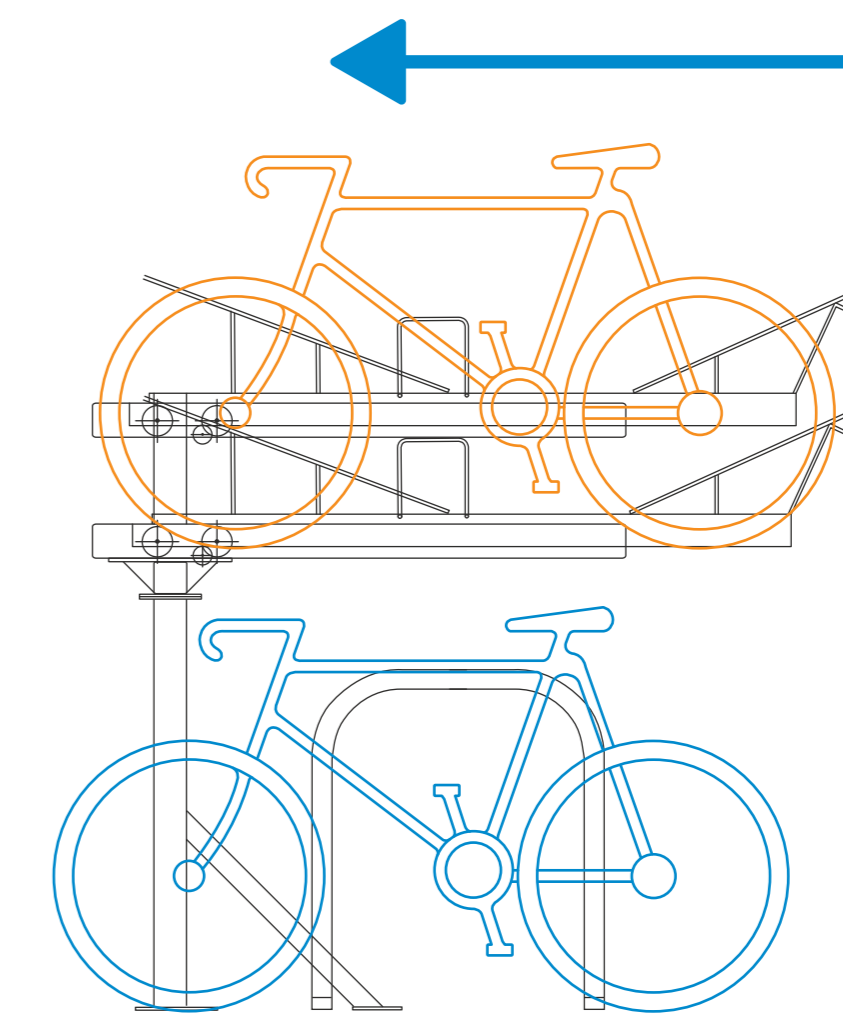

**7** Once the rack is lifted fully from the ground carefully slide the rack back to its fully stowed position.

**8** When using the Sheffield Hoops you may only access or lock up your bicycle if the above rack is fully stowed and there is sufficient space around you to maneuver. Please be aware of restricted head room with the Sheffield Racks.

**WARNING**  
Restricted Head Room  
when using Sheffield  
Cycle Racks

Please report any signs of vandalism or excessive wear to the on-site maintenance team