



Standard Unit Dimensions:

Length: 4100mm
Width: 2200mm
Height: 2536mm

Length with Capacities:

3600mm (8 Cycles)
4100mm (10 Cycles)
5000mm (12 Cycles)

Colours/Finishes:

 Galvanised Only	 RAL 9006 White Aluminium	 RAL 7016 Anthracite Grey
 BS 4800 10 A 07 Nimbus Grey	 RAL 3020 Traffic Red	 RAL 9005 Jet Black
 BS 4800 14 C 39 Holly Green	 RAL 1023 Traffic Yellow	 BS 4800 00 A 05 Goose Grey
 RAL 5015 Mid Blue	 RAL 5013 Dark Blue	 RAL 9016 Traffic White

The colours shown are a guide only.
Please check a colour chart to see the
actual colour.

Product Information

The Farnham Cycle Shelter offers a cantilever design which is strong and durable in construction. Available with or without back panels. When two are used in opposing positions, or when linked together to form banks of shelters to accommodate increased quantities, the Farnham creates a beautiful feature design.

Features

- Robust modular construction
- Welded End Frames and Purlin Section Made From Heavy-Duty Box Section Assembled with Anti-Tamper High Strength Boltsg
- Anti-climb end frames
- Submerged Baseplates
- Hot Dipped Galvanized to BS EN ISO 1461:2009
- 5mm Clear View PETg UV Roof Cladding
- Bream Compliant Configurations

Materials Used

- Framework - Mild Steel
- Cladding - 4 mm PETG uv
- Fasteners - Zinc Plated
- Cover Strips - Pre-galvanized steel flat

Broxap Limited, Rowhurst Industrial Estate, Chesterton, Newcastle-under-Lyme, Staffordshire, ST5 6BD T: 01782 564411 E: info@broxap.com W: www.broxap.com

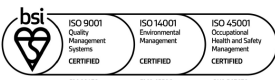

Farnham Cycle Shelter BXMW/FAR

Finish Options

- Galvanised to BS EN ISO 1461:2009
- Galvanised to BS EN ISO 1461:2009 & Polyester Powder Coated

Weather Resistance

Cladding is UV Stabilised
Wind resistant to 23m/s

Fire Resistance

Cladding is fire tested to EN ISO 11925-2

Guarantees, Warranties, Design-Life and Life-Expectancies

- 25 year structural guarantee*
- 34 year (min) life expectancy for Hot Dip Galvanizing
- 8-10 year life expectancy on standard powder coatings
- 10-15 year life expectancy on Duplex (Zinc Coated) powder coatings
- 10 years' manufacturers guarantees* on cladding material(s)
- 10 years' warranty* on material (only)
- 12 months' warranty* on parts & labour

*Maintenance and other qualifying criteria apply

Options

- Back Panels in 5mm PETg UV
- Opal Roof Cladding
- Powder Coating to a wide range of colours
- LED or Solar Lighting
- Multiple Banks to Increase Cycle Capacity
- Full Installation Service
- Internal lighting

Diagram

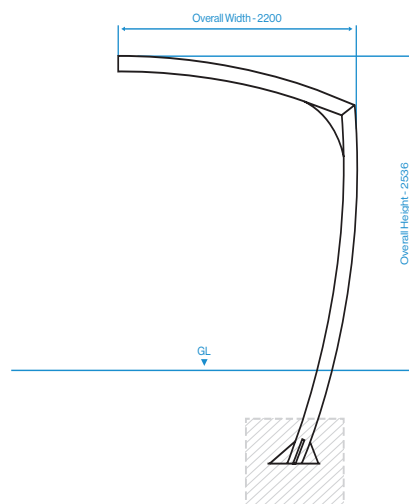

Installation

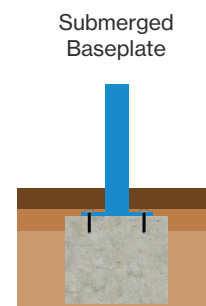









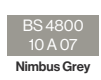

Standard Unit Dimensions:

Length: 4100mm
Width: 2200mm
Height: 2536mm

Length with Capacities:

3600mm (8 Cycles)
4100mm (10 Cycles)
5000mm (12 Cycles)

Colours/Finishes:

The colours shown are a guide only.
Please check a colour chart to see the actual colour.

Broxap Limited, Rowhurst Industrial Estate, Chesterton, Newcastle-under-Lyme, Staffordshire, ST5 6BD T: 01782 564411 E: info@broxap.com W: www.broxap.com

